

FEATURES

- Isolation in Powered-Down Mode, $V_+ = 0$
- Low ON-State Resistance (0.9 Ω)
- Control Inputs Are 5.5-V Tolerant
- Low Charge Injection
- Excellent ON-State Resistance Matching
- Low Total Harmonic Distortion (THD)
- 1.65-V to 5.5-V Single-Supply Operation
- Latch-Up Performance Exceeds 100 mA Per JESD 78, Class II
- ESD Performance Tested Per JESD 22
 - 2000-V Human-Body Model (A114-B, Class II)
 - 1000-V Charged-Device Model (C101)

APPLICATIONS

- Cell Phones
- PDAs
- Portable Instrumentation
- Audio and Video Signal Routing
- Low-Voltage Data-Acquisition Systems
- Communication Circuits
- Modems
- Hard Drives
- Computer Peripherals
- Wireless Terminals and Peripherals

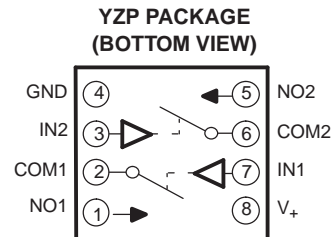
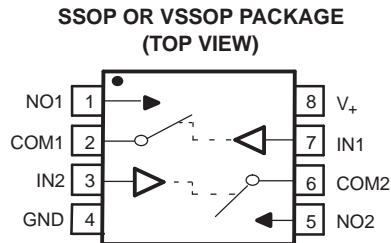

DESCRIPTION/ORDERING INFORMATION

The TS5A23166 is a dual single-pole single-throw (SPST) analog switch that is designed to operate from 1.65 V to 5.5 V. The device offers a low ON-state resistance and an excellent channel-to-channel ON-state resistance matching. The device has excellent total harmonic distortion (THD) performance and consumes very low power. These features make this device suitable for portable audio applications.

ORDERING INFORMATION

T_A	PACKAGE ⁽¹⁾⁽²⁾		ORDERABLE PART NUMBER	TOP-SIDE MARKING ⁽³⁾
–40°C to 85°C	NanoFree™ – WCSP (DSBGA)	Tape and reel	TS5A23166YZPR	JM7
	0.23-mm Large Bump – YZP (Pb-free)			
	SSOP – DCT	Tape and reel	TS5A23166DCTR	PACKAGE PREVIEW
	VSSOP – DCU (Pb-free)	Tape and reel	TS5A23166DCUR	JAM_

- (1) Package drawings, thermal data, and symbolization are available at www.ti.com/packaging.
- (2) For the most current package and ordering information, see the Package Option Addendum at the end of this document, or see the TI website at www.ti.com.
- (3) DCT: The actual top-side marking has three additional characters that designate the year, month, and assembly/test site.
DCU: The actual top-side marking has one additional character that designates the assembly/test site.



Please be aware that an important notice concerning availability, standard warranty, and use in critical applications of Texas Instruments semiconductor products and disclaimers thereto appears at the end of this data sheet.

TS5A23166
0.9-Ω DUAL SPST ANALOG SWITCH
5-V/3.3-V 2-CHANNEL ANALOG SWITCH

SCDS196C–MAY 2005–REVISED NOVEMBER 2007

SUMMARY OF CHARACTERISTICS⁽¹⁾

Configuration	Dual Single Pole, Single Throw (2 × SPST)
Number of channels	2
ON-state resistance (r_{on})	0.9 Ω
ON-state resistance match (Δr_{on})	0.1 Ω
ON-state resistance flatness ($r_{on(Flat)}$)	0.25 Ω
Turn-on/turn-off time (t_{ON}/t_{OFF})	7.5 ns/9 ns
Charge injection (Q_C)	6 pC
Bandwidth (BW)	150 MHz
OFF isolation (O_{ISO})	–62 dB at 1 MHz
Crosstalk (X_{TALK})	–85 dB at 1 MHz
Total harmonic distortion (THD)	0.005%
Leakage current ($I_{COM(OFF)}$)	±20 nA
Power-supply current (I_+)	0.1 μA
Package options	8-pin SSOP, VSSOP, and WCSP

(1) $V_+ = 5\text{ V}$, $T_A = 25^\circ\text{C}$

FUNCTION TABLE

IN	NO TO COM, COM TO NO
L	OFF
H	ON

Absolute Maximum Ratings⁽¹⁾⁽²⁾

over operating free-air temperature range (unless otherwise noted)

		MIN	MAX	UNIT
V_+	Supply voltage range ⁽³⁾	–0.5	6.5	V
V_{NO} V_{COM}	Analog voltage range ⁽³⁾⁽⁴⁾⁽⁵⁾	–0.5	$V_+ + 0.5$	V
I_K	Analog port diode current	$V_{NO}, V_{COM} < 0$		mA
I_{NO} I_{COM}	On-state switch current On-state peak switch current ⁽⁶⁾	$V_{NO}, V_{COM} = 0$ to V_+		mA
V_I	Digital input voltage range ⁽³⁾⁽⁴⁾	–0.5	6.5	V
I_{IK}	Digital input clamp current	$V_I < 0$		mA
I_+	Continuous current through V_+		100	mA
I_{GND}	Continuous current through GND	–100	100	mA
θ_{JA}	Package thermal impedance ⁽⁷⁾	DCT package		220
		DCU package		227
		YZP package		102
T_{stg}	Storage temperature range	–65	150	°C

- (1) Stresses beyond those listed under "absolute maximum ratings" may cause permanent damage to the device. These are stress ratings only, and functional operation of the device at these or any other conditions beyond those indicated under "recommended operating conditions" is not implied. Exposure to absolute-maximum-rated conditions for extended periods may affect device reliability.
- (2) The algebraic convention, whereby the most negative value is a minimum and the most positive value is a maximum
- (3) All voltages are with respect to ground, unless otherwise specified.
- (4) The input and output voltage ratings may be exceeded if the input and output clamp-current ratings are observed.
- (5) This value is limited to 5.5 V maximum.
- (6) Pulse at 1-ms duration < 10% duty cycle.
- (7) The package thermal impedance is calculated in accordance with JESD 51-7.

Electrical Characteristics for 5-V Supply⁽¹⁾

$V_+ = 4.5\text{ V to }5.5\text{ V}$, $T_A = -40^\circ\text{C to }85^\circ\text{C}$ (unless otherwise noted)

PARAMETER	SYMBOL	TEST CONDITIONS	T_A	V_+	MIN	TYP	MAX	UNIT	
Analog Switch									
Analog signal range	V_{COM}, V_{NO}				0		V_+	V	
Peak ON resistance	r_{peak}	$0 \leq V_{NO} \leq V_+$, $I_{COM} = -100\text{ mA}$,	Switch ON, See Figure 12	25°C	4.5 V	0.9	1.1	Ω	
				Full		1.2			
ON-state resistance	r_{on}	$V_{NO} = 2.5\text{ V}$, $I_{COM} = -100\text{ mA}$,	Switch ON, See Figure 12	25°C	4.5 V	0.75	0.9	Ω	
				Full		1			
ON-state resistance match between channels	Δr_{on}	$V_{NO} = 2.5\text{ V}$, $I_{COM} = -100\text{ mA}$,	Switch ON, See Figure 12	25°C	4.5 V	0.04	0.1	Ω	
				Full		0.1			
ON-state resistance flatness	$r_{on(Flat)}$	$0 \leq V_{NO} \leq V_+$, $I_{COM} = -100\text{ mA}$,	Switch ON, See Figure 12	25°C	4.5 V	0.2		Ω	
				25°C		0.15	0.25		
				Full		0.25			
NO OFF leakage current	$I_{NO(OFF)}$	$V_{NO} = 1\text{ V}$, $V_{COM} = 4.5\text{ V}$, or $V_{NO} = 4.5\text{ V}$, $V_{COM} = 1\text{ V}$,	Switch OFF, See Figure 13	25°C	5.5 V	0 V	4	20	nA
				Full		-150	150		
	$I_{NO(PWROFF)}$	$V_{NO} = 0\text{ to }5.5\text{ V}$, $V_{COM} = 5.5\text{ V to }0$,	Switch OFF, See Figure 13	25°C	0 V	-10	0.2	10	μA
				Full		-50	50		
COM OFF leakage current	$I_{COM(OFF)}$	$V_{COM} = 1\text{ V}$, $V_{NO} = 4.5\text{ V}$, or $V_{COM} = 4.5\text{ V}$, $V_{NO} = 1\text{ V}$,	Switch OFF, See Figure 13	25°C	5.5 V	0 V	4	20	nA
				Full		-150	150		
	$I_{COM(PWROFF)}$	$V_{COM} = 0\text{ to }5.5\text{ V}$, $V_{NO} = 5.5\text{ V to }0$,	Switch OFF, See Figure 13	25°C	0 V	-10	0.2	10	μA
				Full		-50	50		
NO ON leakage current	$I_{NO(ON)}$	$V_{NO} = 1\text{ V}$, $V_{COM} = \text{Open}$, or $V_{NO} = 4.5\text{ V}$, $V_{COM} = \text{Open}$,	Switch ON, See Figure 14	25°C	5.5 V	-5	0.4	5	nA
				Full		-50	50		
COM ON leakage current	$I_{COM(ON)}$	$V_{COM} = 1\text{ V}$, $V_{NO} = \text{Open}$, or $V_{COM} = 4.5\text{ V}$, $V_{NO} = \text{Open}$,	Switch ON, See Figure 14	25°C	5.5 V	-5	0.4	5	nA
				Full		-50	50		
Digital Control Inputs (IN1, IN2)⁽²⁾									
Input logic high	V_{IH}		Full		2.4		5.5	V	
Input logic low	V_{IL}		Full		0		0.8	V	
Input leakage current	I_{IH}, I_{IL}	$V_I = 5.5\text{ V or }0$	25°C	5.5 V	-2	0.3	2	nA	
			Full		-20	20			

(1) The algebraic convention, whereby the most negative value is a minimum and the most positive value is a maximum

(2) All unused digital inputs of the device must be held at V_+ or GND to ensure proper device operation. Refer to the TI application report, *Implications of Slow or Floating CMOS Inputs*, literature number SCBA004.

TS5A23166
0.9-Ω DUAL SPST ANALOG SWITCH
5-V/3.3-V 2-CHANNEL ANALOG SWITCH

SCDS196C–MAY 2005–REVISED NOVEMBER 2007

Electrical Characteristics for 5-V Supply⁽¹⁾ (continued)

$V_+ = 4.5\text{ V to }5.5\text{ V}$, $T_A = -40^\circ\text{C to }85^\circ\text{C}$ (unless otherwise noted)

PARAMETER	SYMBOL	TEST CONDITIONS	T_A	V_+	MIN	TYP	MAX	UNIT
Dynamic								
Turn-on time	t_{ON}	$V_{COM} = V_+$, $R_L = 50\ \Omega$, $C_L = 35\text{ pF}$, See Figure 16	25°C	5 V	1	4.5	7.5	ns
			Full	4.5 V to 5.5 V	1		9	
Turn-off time	t_{OFF}	$V_{COM} = V_+$, $R_L = 50\ \Omega$, $C_L = 35\text{ pF}$, See Figure 16	25°C	5 V	4.5	8	11	ns
			Full	4.5 V to 5.5 V	3.5		13	
Charge injection	Q_C	$V_{GEN} = 0$, $R_{GEN} = 0$, $C_L = 1\text{ nF}$, See Figure 20	25°C	5 V		6		pC
NO OFF capacitance	$C_{NO(OFF)}$	$V_{NO} = V_+$ or GND, Switch OFF, See Figure 15	25°C	5 V		19		pF
COM OFF capacitance	$C_{COM(OFF)}$	$V_{COM} = V_+$ or GND, Switch OFF, See Figure 15	25°C	5 V		18		pF
NO ON capacitance	$C_{NO(ON)}$	$V_{NO} = V_+$ or GND, Switch ON, See Figure 15	25°C	5 V		35.5		pF
COM ON capacitance	$C_{COM(ON)}$	$V_{COM} = V_+$ or GND, Switch ON, See Figure 15	25°C	5 V		35.5		pF
Digital input capacitance	C_I	$V_I = V_+$ or GND, See Figure 15	25°C	5 V		2		pF
Bandwidth	BW	$R_L = 50\ \Omega$, Switch ON, See Figure 17	25°C	5 V		150		MHz
OFF isolation	O_{ISO}	$R_L = 50\ \Omega$, $f = 1\text{ MHz}$, Switch OFF, See Figure 18	25°C	5 V		-62		dB
Crosstalk	X_{TALK}	$R_L = 50\ \Omega$, $f = 1\text{ MHz}$, Switch ON, See Figure 19	25°C	5 V		-85		dB
Total harmonic distortion	THD	$R_L = 600\ \Omega$, $C_L = 50\text{ pF}$, $f = 20\text{ Hz to }20\text{ kHz}$, See Figure 21	25°C	5 V		0.005		%
Supply								
Positive supply current	I_+	$V_I = V_+$ or GND, Switch ON or OFF	25°C	5.5 V		0.01	0.1	μA
			Full				1	

(1) The algebraic convention, whereby the most negative value is a minimum and the most positive value is a maximum

Electrical Characteristics for 3.3-V Supply⁽¹⁾

$V_+ = 3\text{ V to }3.6\text{ V}$, $T_A = -40^\circ\text{C to }85^\circ\text{C}$ (unless otherwise noted)

PARAMETER	SYMBOL	TEST CONDITIONS	T_A	V_+	MIN	TYP	MAX	UNIT	
Analog Switch									
Analog signal range	V_{COM}, V_{NO}				0		V_+	V	
Peak ON resistance	r_{peak}	$0 \leq V_{NO} \leq V_+$, $I_{COM} = -100\text{ mA}$, Switch ON, See Figure 12	25°C	3 V		1.3	1.6	Ω	
			Full			1.8			
ON-state resistance	r_{on}	$V_{NO} = 2\text{ V}$, $I_{COM} = -100\text{ mA}$, Switch ON, See Figure 12	25°C	3 V		1.1	1.5	Ω	
			Full			1.7			
ON-state resistance match between channels	Δr_{on}	$V_{NO} = 2\text{ V}, 0.8\text{ V}$, $I_{COM} = -100\text{ mA}$, Switch ON, See Figure 12	25°C	3 V		0.04	0.1	Ω	
			Full			0.1			
ON-state resistance flatness	$r_{on(Flat)}$	$0 \leq V_{NO} \leq V_+$, $I_{COM} = -100\text{ mA}$, Switch ON, See Figure 12	25°C	3 V		0.3		Ω	
			25°C			0.15	0.25		
			Full			0.25			
NO OFF leakage current	$I_{NO(OFF)}$	$V_{NO} = 1\text{ V}, V_{COM} = 3\text{ V}$, or $V_{NO} = 3\text{ V}, V_{COM} = 1\text{ V}$, Switch OFF, See Figure 13	25°C	3.6 V		-5	0.5	5	nA
			Full			-50	50		
	$I_{NO(PWROFF)}$	$V_{NO} = 0\text{ to }3.6\text{ V}$, $V_{COM} = 3.6\text{ V to }0$, Switch OFF, See Figure 13	25°C	0 V		-5	0.1	5	μA
			Full			-25	25		
COM OFF leakage current	$I_{COM(OFF)}$	$V_{COM} = 1\text{ V}, V_{NO} = 3\text{ V}$, or $V_{COM} = 3\text{ V}, V_{NO} = 1\text{ V}$, Switch OFF, See Figure 13	25°C	3.6 V		-5	0.5	5	nA
			Full			-50	50		
	$I_{COM(PWROFF)}$	$V_{COM} = 0\text{ to }3.6\text{ V}$, $V_{NO} = 3.6\text{ V to }0$, Switch OFF, See Figure 13	25°C	0 V		-5	0.1	5	μA
			Full			-25	25		
NO ON leakage current	$I_{NO(ON)}$	$V_{NO} = 1\text{ V}$, $V_{COM} = \text{Open}$, or $V_{NO} = 3\text{ V}$, $V_{COM} = \text{Open}$, Switch ON, See Figure 14	25°C	3.6 V		-2	0.3	2	nA
			Full			-20	20		
COM ON leakage current	$I_{COM(ON)}$	$V_{COM} = 1\text{ V}$, $V_{NO} = \text{Open}$, or $V_{COM} = 3\text{ V}$, $V_{NO} = \text{Open}$, Switch ON, See Figure 14	25°C	3.6 V		-2	0.3	2	nA
			Full			-20	20		
Digital Control Inputs (IN1, IN2)⁽²⁾									
Input logic high	V_{IH}		Full			2	5.5	V	
Input logic low	V_{IL}		Full			0	0.8	V	
Input leakage current	I_{IH}, I_{IL}	$V_I = 5.5\text{ V or }0$	25°C	3.6 V		-2	0.3	2	nA
			Full			-20	20		

(1) The algebraic convention, whereby the most negative value is a minimum and the most positive value is a maximum

(2) All unused digital inputs of the device must be held at V_+ or GND to ensure proper device operation. Refer to the TI application report, *Implications of Slow or Floating CMOS Inputs*, literature number SCBA004.

TS5A23166
0.9-Ω DUAL SPST ANALOG SWITCH
5-V/3.3-V 2-CHANNEL ANALOG SWITCH

SCDS196C–MAY 2005–REVISED NOVEMBER 2007

Electrical Characteristics for 3.3-V Supply⁽¹⁾ (continued)

$V_+ = 3\text{ V to }3.6\text{ V}$, $T_A = -40^\circ\text{C to }85^\circ\text{C}$ (unless otherwise noted)

PARAMETER	SYMBOL	TEST CONDITIONS	T_A	V_+	MIN	TYP	MAX	UNIT
Dynamic								
Turn-on time	t_{ON}	$V_{COM} = V_+$, $R_L = 50\ \Omega$, $C_L = 35\text{ pF}$, See Figure 16	25°C	3.3 V	1.5	5	9.5	ns
			Full	3 V to 3.6 V	1		10	
Turn-off time	t_{OFF}	$V_{COM} = V_+$, $R_L = 50\ \Omega$, $C_L = 35\text{ pF}$, See Figure 16	25°C	3.3 V	4.5	8.5	11	ns
			Full	3 V to 3.6 V	3		12.5	
Charge injection	Q_C	$V_{GEN} = 0$, $R_{GEN} = 0$, $C_L = 1\text{ nF}$, See Figure 20	25°C	5 V		6		pC
NO OFF capacitance	$C_{NO(OFF)}$	$V_{NO} = V_+$ or GND, Switch OFF, See Figure 15	25°C	3.3 V		19.5		pF
COM OFF capacitance	$C_{COM(OFF)}$	$V_{COM} = V_+$ or GND, Switch OFF, See Figure 15	25°C	3.3 V		18.5		pF
NO ON capacitance	$C_{NO(ON)}$	$V_{NO} = V_+$ or GND, Switch ON, See Figure 15	25°C	3.3 V		36		pF
COM ON capacitance	$C_{COM(ON)}$	$V_{COM} = V_+$ or GND, Switch ON, See Figure 15	25°C	3.3 V		36		pF
Digital input capacitance	C_I	$V_I = V_+$ or GND, See Figure 15	25°C	3.3 V		2		pF
Bandwidth	BW	$R_L = 50\ \Omega$, Switch ON, See Figure 17	25°C	3.3 V		150		MHz
OFF isolation	O_{ISO}	$R_L = 50\ \Omega$, $f = 1\text{ MHz}$, Switch OFF, See Figure 18	25°C	3.3 V		-62		dB
Crosstalk	X_{TALK}	$R_L = 50\ \Omega$, $f = 1\text{ MHz}$, Switch ON, See Figure 19	25°C	3.3 V		-85		dB
Total harmonic distortion	THD	$R_L = 600\ \Omega$, $C_L = 50\text{ pF}$, $f = 20\text{ Hz to }20\text{ kHz}$, See Figure 21	25°C	3.3 V		0.01		%
Supply								
Positive supply current	I_+	$V_I = V_+$ or GND, Switch ON or OFF	25°C	3.6 V	0.001	0.05	0.3	μA
			Full					

(1) The algebraic convention, whereby the most negative value is a minimum and the most positive value is a maximum

Electrical Characteristics for 2.5-V Supply⁽¹⁾
 $V_+ = 2.3 \text{ V to } 2.7 \text{ V}$, $T_A = -40^\circ\text{C to } 85^\circ\text{C}$ (unless otherwise noted)

PARAMETER	SYMBOL	TEST CONDITIONS	T_A	V_+	MIN	TYP	MAX	UNIT	
Analog Switch									
Analog signal range	V_{COM}, V_{NO}				0		V_+	V	
Peak ON resistance	r_{peak}	$0 \leq V_{NO} \leq V_+$, $I_{COM} = -8 \text{ mA}$,	Switch ON, See Figure 12	25°C	2.3 V	1.8	2.4	Ω	
				Full					2.6
ON-state resistance	r_{on}	$V_{NO} = 1.8 \text{ V}$, $I_{COM} = -8 \text{ mA}$,	Switch ON, See Figure 12	25°C	2.3 V	1.2	2.1	Ω	
				Full					2.4
ON-state resistance match between channels	Δr_{on}	$V_{NO} = 1.8 \text{ V}$, 0.8 V, $I_{COM} = -8 \text{ mA}$,	Switch ON, See Figure 12	25°C	2.3 V	0.04	0.15	Ω	
				Full		0.15			
ON-state resistance flatness	$r_{on (flat)}$	$0 \leq V_{NO} \leq V_+$, $I_{COM} = -8 \text{ mA}$,	Switch ON, See Figure 12	25°C	2.3 V	0.7	0.6	Ω	
				25°C					0.4
				Full					
NO OFF leakage current	$I_{NO(OFF)}$	$V_{NO} = 0.5 \text{ V}$, $V_{COM} = 2.3 \text{ V}$, or $V_{NO} = 2.3 \text{ V}$, $V_{COM} = 0.5 \text{ V}$,	Switch OFF, See Figure 13	25°C	2.7 V	-5	0.3	5	nA
				Full		-50	50		
	$I_{NO(PWROFF)}$	$V_{NO} = 0 \text{ to } 2.7 \text{ V}$, $V_{COM} = 2.7 \text{ V to } 0$,	Switch OFF, See Figure 13	25°C	0 V	-2	0.05	2	μA
				Full		-15	15		
COM OFF leakage current	$I_{COM(OFF)}$	$V_{NO} = 2.3 \text{ V}$, $V_{COM} = 0.5 \text{ V}$, or $V_{NO} = 0.5 \text{ V}$, $V_{COM} = 2.3 \text{ V}$,	Switch OFF, See Figure 13	25°C	2.7 V	-5	0.3	5	nA
				Full		-50	50		
	$I_{COM(PWROFF)}$	$V_{COM} = 0 \text{ to } 2.7 \text{ V}$, $V_{NO} = 2.7 \text{ V to } 0$,	Switch OFF, See Figure 13	25°C	0 V	-2	0.05	2	μA
				Full		-15	15		
NO ON leakage current	$I_{NO(ON)}$	$V_{NO} = 0.5 \text{ V}$, $V_{COM} = \text{Open}$, or $V_{NO} = 2.3 \text{ V}$, $V_{COM} = \text{Open}$,	Switch ON, See Figure 14	25°C	2.7 V	-2	0.3	2	nA
				Full		-20	20		
COM ON leakage current	$I_{COM(ON)}$	$V_{COM} = 0.5 \text{ V}$, $V_{NO} = \text{Open}$, or $V_{COM} = 2.3 \text{ V}$, $V_{NO} = \text{Open}$,	Switch ON, See Figure 14	25°C	2.7 V	-2	0.3	2	nA
				Full		-20	20		
Digital Control Inputs (IN1, IN2)									
Input logic high	V_{IH}			Full		1.8	5.5	V	
Input logic low	V_{IL}			Full		0	0.6	V	
Input leakage current	I_{IH}, I_{IL}	$V_I = 5.5 \text{ V or } 0$		25°C	2.7 V	-2	0.3	2	nA
				Full		-20	20		

(1) The algebraic convention is used in this data sheet; the most negative value is shown in the minimum column.

TS5A23166
0.9-Ω DUAL SPST ANALOG SWITCH
5-V/3.3-V 2-CHANNEL ANALOG SWITCH

SCDS196C–MAY 2005–REVISED NOVEMBER 2007

Electrical Characteristics for 2.5-V Supply⁽¹⁾ (continued)

$V_+ = 2.3 \text{ V to } 2.7 \text{ V}$, $T_A = -40^\circ\text{C to } 85^\circ\text{C}$ (unless otherwise noted)

PARAMETER	SYMBOL	TEST CONDITIONS	T_A	V_+	MIN	TYP	MAX	UNIT
Dynamic								
Turn-on time	t_{ON}	$V_{COM} = V_+$, $R_L = 50 \Omega$, $C_L = 35 \text{ pF}$, See Figure 16	25°C	2.5 V	2	6	10	ns
			Full	2.3 V to 2.7 V	1		12	
Turn-off time	t_{OFF}	$V_{COM} = V_+$, $R_L = 50 \Omega$, $C_L = 35 \text{ pF}$, See Figure 16	25°C	2.5 V	4.5	8	12.5	ns
			Full	2.3 V to 2.7 V	3		15	
Charge injection	Q_C	$V_{GEN} = 0$, $R_{GEN} = 0$, $C_L = 1 \text{ nF}$, See Figure 20	25°C	2.5 V		4		pC
NO OFF capacitance	$C_{NO(OFF)}$	$V_{NO} = V_+$ or GND, Switch OFF, See Figure 15	25°C	2.5 V		19.5		pF
COM OFF capacitance	$C_{COM(OFF)}$	$V_{COM} = V_+$ or GND, Switch OFF, See Figure 15	25°C	2.5 V		18.5		pF
NO ON capacitance	$C_{NO(ON)}$	$V_{NO} = V_+$ or GND, Switch ON, See Figure 15	25°C	2.5 V		36.5		pF
COM ON capacitance	$C_{COM(ON)}$	$V_{COM} = V_+$ or GND, Switch ON, See Figure 15	25°C	2.5 V		36.5		pF
Digital input capacitance	C_I	$V_I = V_+$ or GND, See Figure 15	25°C	2.5 V		2		pF
Bandwidth	BW	$R_L = 50 \Omega$, Switch ON, See Figure 17	25°C	2.5 V		150		MHz
OFF isolation	O_{ISO}	$R_L = 50 \Omega$, $f = 1 \text{ MHz}$, Switch OFF, See Figure 18	25°C	2.5 V		-62		dB
Crosstalk	X_{TALK}	$R_L = 50 \Omega$, $f = 1 \text{ MHz}$, Switch ON, See Figure 19	25°C	2.5 V		-85		dB
Total harmonic distortion	THD	$R_L = 600 \Omega$, $C_L = 50 \text{ pF}$, $f = 20 \text{ Hz to } 20 \text{ kHz}$, See Figure 21	25°C	2.5 V		0.02		%
Supply								
Positive supply current	I_+	$V_I = V_+$ or GND, Switch ON or OFF	25°C	2.7 V		0.001	0.02	μA
			Full				0.25	

(1) The algebraic convention is used in this data sheet; the most negative value is shown in the minimum column.

Electrical Characteristics for 1.8-V Supply⁽¹⁾

$V_+ = 1.65\text{ V to }1.95\text{ V}$, $T_A = -40^\circ\text{C to }85^\circ\text{C}$ (unless otherwise noted)

PARAMETER	SYMBOL	TEST CONDITIONS	T_A	V_+	MIN	TYP	MAX	UNIT
Analog Switch								
Analog signal range	V_{COM}, V_{NO}				0		V_+	V
Peak ON resistance	r_{peak}	$0 \leq V_{NO} \leq V_+$, $I_{COM} = -2\text{ mA}$, Switch ON, See Figure 12	25°C	1.65 V	4.2		25	Ω
			Full				30	
ON-state resistance	r_{on}	$V_{NO} = 0.6\text{ V}, 1.5\text{ V}$, $I_{COM} = -2\text{ mA}$, Switch ON, See Figure 12	25°C	1.65 V	1.6		3.9	Ω
			Full				4	
ON-state resistance match between channels	Δr_{on}	$V_{NO} = 1.5\text{ V}$, $I_{COM} = -2\text{ mA}$, Switch ON, See Figure 12	25°C	1.65 V	0.04		0.2	Ω
			Full				0.2	
ON-state resistance flatness	$r_{on (flat)}$	$0 \leq V_{NO} \leq V_+$, $I_{COM} = -2\text{ mA}$, Switch ON, See Figure 12	25°C	1.65 V	2.8			Ω
			Full				27	
NO OFF leakage current	$I_{NO(OFF)}$	$V_{NO} = 0.3\text{ V}$, $V_{COM} = 1.65\text{ V}$, or $V_{NO} = 1.65\text{ V}$, $V_{COM} = 0.3\text{ V}$, Switch OFF, See Figure 13	25°C	1.95 V	-5	0.3	5	nA
			Full				50	
	$I_{NO(PWROFF)}$	$V_{NO} = 0\text{ to }1.95\text{ V}$, $V_{COM} = 1.95\text{ V to }0$, Switch OFF, See Figure 13	25°C	0 V	-2	0.05	2	μA
			Full				10	
COM OFF leakage current	$I_{COM(OFF)}$	$V_{NO} = 1.65\text{ V}$, $V_{COM} = 0.3\text{ V}$, or $V_{NO} = 0.3\text{ V}$, $V_{COM} = 1.65\text{ V}$, Switch OFF, See Figure 13	25°C	1.95 V	-5	0.3	5	nA
			Full				50	
	$I_{COM(PWROFF)}$	$V_{COM} = 0\text{ to }1.95\text{ V}$, $V_{NO} = 1.95\text{ V to }0$, Switch OFF, See Figure 13	25°C	0 V	-2	0.05	2	μA
			Full				10	
NO ON leakage current	$I_{NO(ON)}$	$V_{NO} = 0.3\text{ V}$, $V_{COM} = \text{Open}$, or $V_{NO} = 1.65\text{ V}$, $V_{COM} = \text{Open}$, Switch ON, See Figure 14	25°C	1.95 V	-2	0.3	2	nA
			Full				20	
COM ON leakage current	$I_{COM(ON)}$	$V_{NO} = \text{Open}$, $V_{COM} = 0.3\text{ V}$, or $V_{NO} = \text{Open}$, $V_{COM} = 1.65\text{ V}$, Switch ON, See Figure 14	25°C	1.95 V	-2	0.3	2	nA
			Full				20	
Digital Control Inputs (IN1, IN2)								
Input logic high	V_{IH}		Full		1.5		5.5	V
Input logic low	V_{IL}		Full		0		0.6	V
Input leakage current	I_{IH}, I_{IL}	$V_I = 5.5\text{ V or }0$	25°C	1.95 V	-2	0.3	2	μA
			Full				20	

(1) The algebraic convention is used in this data sheet; the most negative value is shown in the minimum column.

TS5A23166
0.9-Ω DUAL SPST ANALOG SWITCH
5-V/3.3-V 2-CHANNEL ANALOG SWITCH

SCDS196C–MAY 2005–REVISED NOVEMBER 2007

Electrical Characteristics for 1.8-V Supply⁽¹⁾ (continued)

$V_+ = 1.65\text{ V to }1.95\text{ V}$, $T_A = -40^\circ\text{C to }85^\circ\text{C}$ (unless otherwise noted)

PARAMETER	SYMBOL	TEST CONDITIONS	T_A	V_+	MIN	TYP	MAX	UNIT	
Dynamic									
Turn-on time	t_{ON}	$V_{COM} = V_+$, $R_L = 50\ \Omega$,	$C_L = 35\text{ pF}$, See Figure 16	25°C	1.8 V	3	9	18	ns
				Full	1.65 V to 1.95 V	1		20	
Turn-off time	t_{OFF}	$V_{COM} = V_+$, $R_L = 50\ \Omega$,	$C_L = 35\text{ pF}$, See Figure 16	25°C	1.8 V	5	10	15.5	ns
				Full	1.65 V to 1.95 V	4		18.5	
Charge injection	Q_C	$V_{GEN} = 0$, $R_{GEN} = 0$,	$C_L = 1\text{ nF}$, See Figure 20	25°C	1.8 V		2	pC	
NO OFF capacitance	$C_{NO(OFF)}$	$V_{NO} = V_+$ or GND, Switch OFF,	See Figure 15	25°C	1.8 V		19.5	pF	
COM OFF capacitance	$C_{COM(OFF)}$	$V_{COM} = V_+$ or GND, Switch OFF,	See Figure 15	25°C	1.8 V		18.5	pF	
NO ON capacitance	$C_{NO(ON)}$	$V_{NO} = V_+$ or GND, Switch ON,	See Figure 15	25°C	1.8 V		36.5	pF	
COM ON capacitance	$C_{COM(ON)}$	$V_{COM} = V_+$ or GND, Switch ON,	See Figure 15	25°C	1.8 V		36.5	pF	
Digital input capacitance	C_I	$V_I = V_+$ or GND,	See Figure 15	25°C	1.8 V		2	pF	
Bandwidth	BW	$R_L = 50\ \Omega$, Switch ON,	See Figure 17	25°C	1.8 V		150	MHz	
OFF isolation	O_{ISO}	$R_L = 50\ \Omega$, $f = 1\text{ MHz}$,	Switch OFF, See Figure 18	25°C	1.8 V		-62	dB	
Total harmonic distortion	THD	$R_L = 600\ \Omega$, $C_L = 50\text{ pF}$,	$f = 20\text{ Hz to }20\text{ kHz}$, See Figure 21	25°C	1.8 V		0.055	%	
Supply									
Positive supply current	I_+	$V_I = V_+$ or GND,	Switch ON or OFF	25°C	1.95 V		0.001	0.01	μA
				Full				0.15	

(1) The algebraic convention is used in this data sheet; the most negative value is shown in the minimum column.

TYPICAL PERFORMANCE

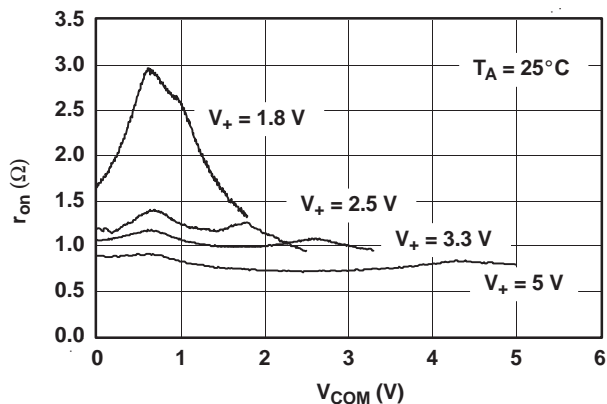

Figure 1. r_{on} vs V_{COM}

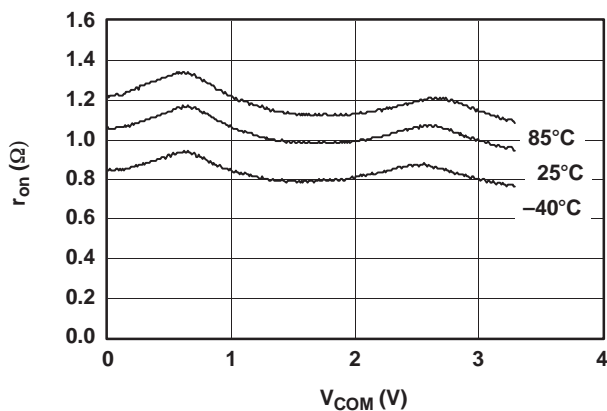

Figure 2. r_{on} vs V_{COM} ($V_+ = 3.3\text{ V}$)

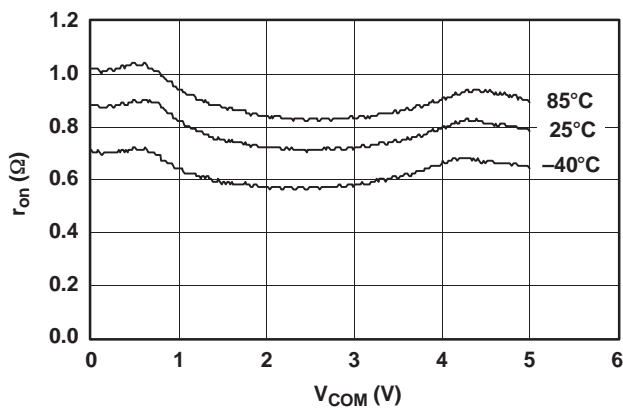

Figure 3. r_{on} vs V_{COM} ($V_+ = 5\text{ V}$)

TYPICAL PERFORMANCE

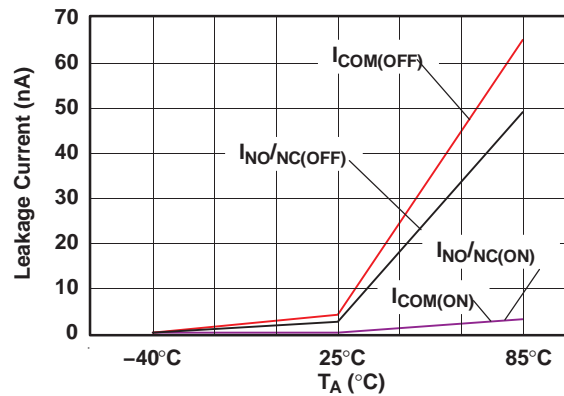

Figure 4. Leakage Current vs Temperature ($V_+ = 5.5\text{ V}$)

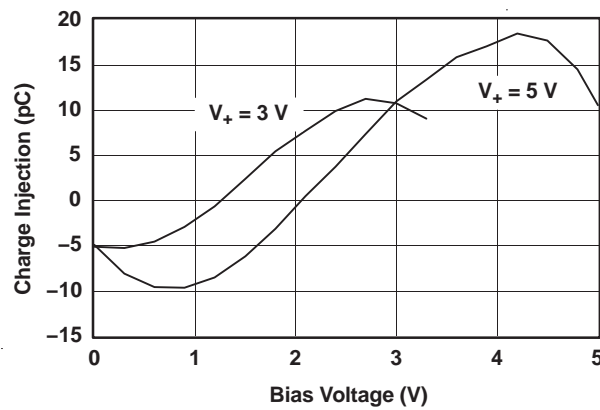

Figure 5. Charge Injection (Q_C) vs V_{COM}

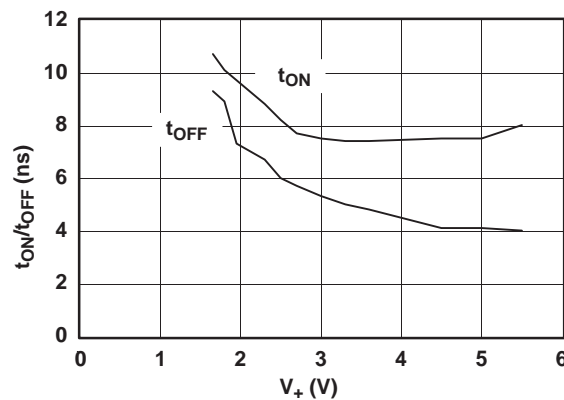

Figure 6. t_{ON} and t_{OFF} vs Supply Voltage

TYPICAL PERFORMANCE (continued)

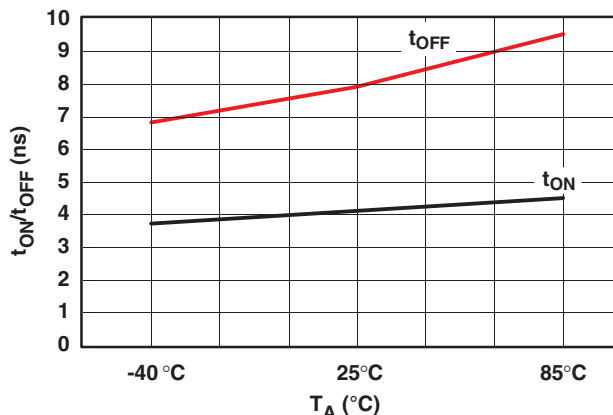

Figure 7. t_{ON} and t_{OFF} vs Temperature ($V_+ = 5$ V)

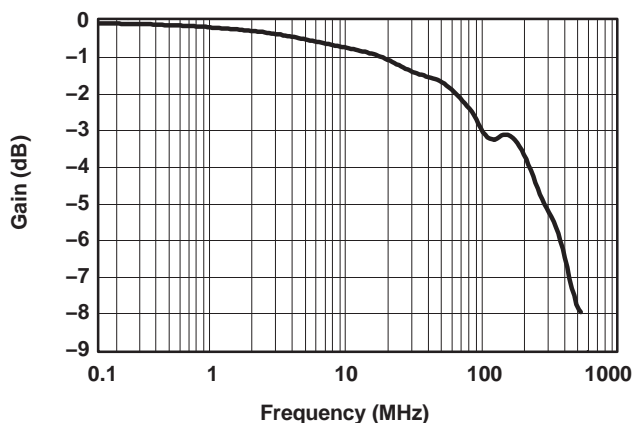

Figure 8. Bandwidth ($V_+ = 5$ V)

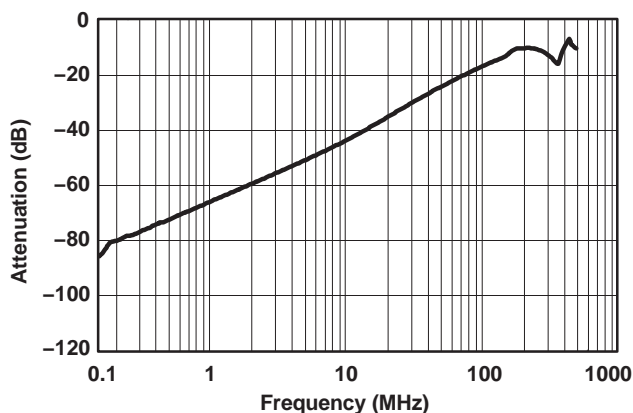

Figure 9. OFF Isolation and Crosstalk ($V_+ = 5$ V)

TYPICAL PERFORMANCE (continued)

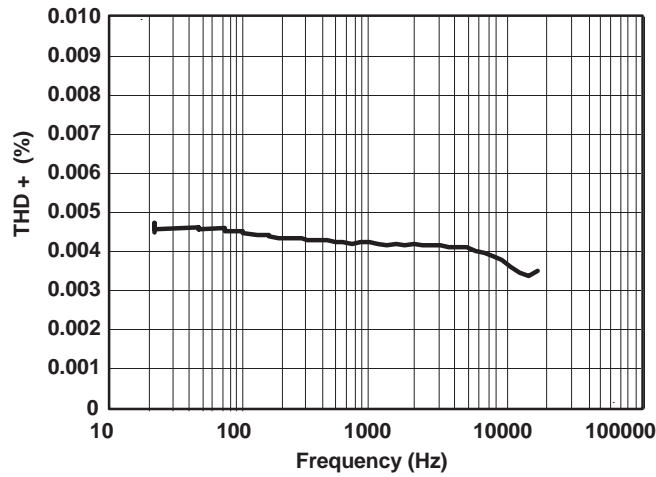

Figure 10. Total Harmonic Distortion vs Frequency

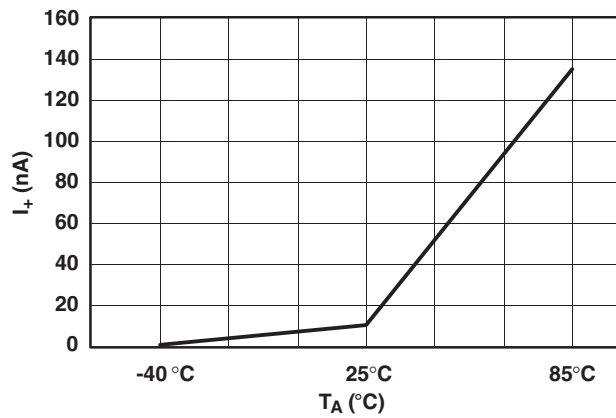

Figure 11. Power-Supply Current vs Temperature ($V_+ = 5\text{ V}$)

PIN DESCRIPTION

PIN NUMBER	NAME	DESCRIPTION
1	NO1	Normally closed
2	COM1	Common
3	IN2	Digital control pin to connect COM to NO
4	GND	Digital ground
5	NO2	Normally closed
6	COM2	Common
7	IN1	Digital control pin to connect COM to NO
8	V+	Power Supply

PARAMETER DESCRIPTION

SYMBOL	DESCRIPTION
V_{COM}	Voltage at COM
V_{NO}	Voltage at NO
r_{on}	Resistance between COM and NO ports when the channel is ON
$r_{on(Flat)}$	Difference between the maximum and minimum value of r_{on} in a channel over the specified range of conditions
$I_{NO(OFF)}$	Leakage current measured at the NO port, with the corresponding channel (NO to COM) in the OFF state
$I_{NO(ON)}$	Leakage current measured at the NO port, with the corresponding channel (NO to COM) in the ON state and the output (COM) open
$I_{COM(OFF)}$	Leakage current measured at the COM port, with the corresponding channel (COM to NO) in the OFF state
$I_{COM(ON)}$	Leakage current measured at the COM port, with the corresponding channel (COM to NO) in the ON state and the output (NO) open
V_{IH}	Minimum input voltage for logic high for the control input (IN)
V_{IL}	Maximum input voltage for logic low for the control input (IN)
V_I	Voltage at the control input (IN)
I_{IH}, I_{IL}	Leakage current measured at the control input (IN)
t_{ON}	Turn-on time for the switch. This parameter is measured under the specified range of conditions and by the propagation delay between the digital control (IN) signal and analog output (COM or NO) signal when the switch is turning ON.
t_{OFF}	Turn-off time for the switch. This parameter is measured under the specified range of conditions and by the propagation delay between the digital control (IN) signal and analog output (COM or NO) signal when the switch is turning OFF.
Q_C	Charge injection is a measurement of unwanted signal coupling from the control (IN) input to the analog (NO or COM) output. This is measured in coulomb (C) and measured by the total charge induced due to switching of the control input. Charge injection, $Q_C = C_L \times \Delta V_{COM}$, C_L is the load capacitance and ΔV_{COM} is the change in analog output voltage.
$C_{NO(OFF)}$	Capacitance at the NO port when the corresponding channel (NO to COM) is OFF
$C_{NO(ON)}$	Capacitance at the NO port when the corresponding channel (NO to COM) is ON
$C_{COM(OFF)}$	Capacitance at the COM port when the corresponding channel (COM to NO) is OFF
$C_{COM(ON)}$	Capacitance at the COM port when the corresponding channel (COM to NO) is ON
C_I	Capacitance of IN
O_{ISO}	OFF isolation of the switch is a measurement of OFF-state switch impedance. This is measured in dB in a specific frequency, with the corresponding channel (NO to COM) in the OFF state.
BW	Bandwidth of the switch. This is the frequency in which the gain of an ON channel is –3 dB below the DC gain.
THD	Total harmonic distortion is defined as the ratio of the root mean square (RMS) value of the second, third, and higher harmonics to the magnitude of fundamental harmonic.
I_+	Static power-supply current with the control (IN) pin at V_+ or GND
ΔI_+	This is the increase in I_+ for each control (IN) input that is at the specified voltage, rather than at V_+ or GND.

PARAMETER MEASUREMENT INFORMATION

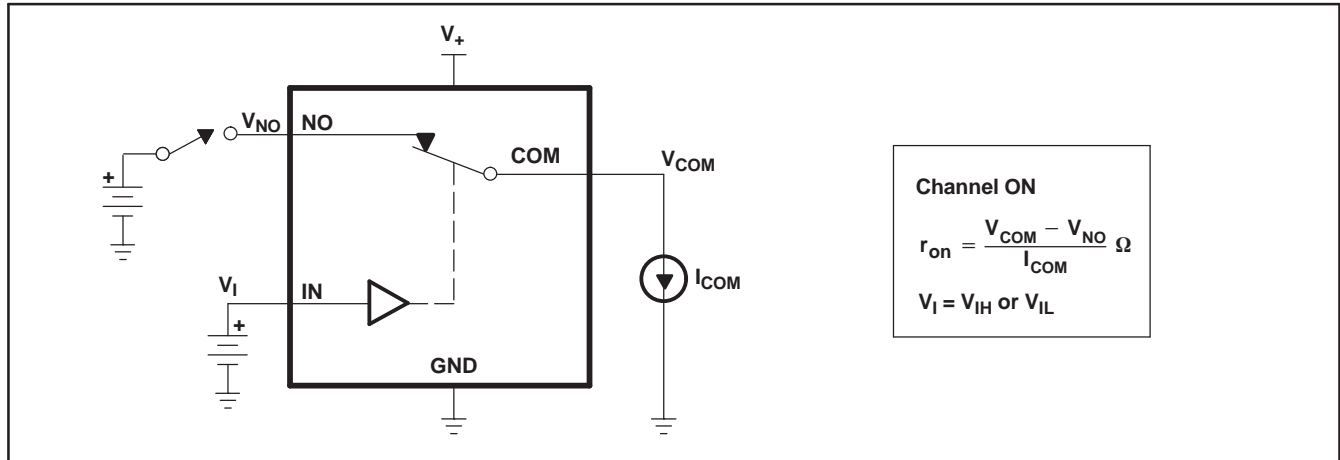

Figure 12. ON-State Resistance (r_{on})

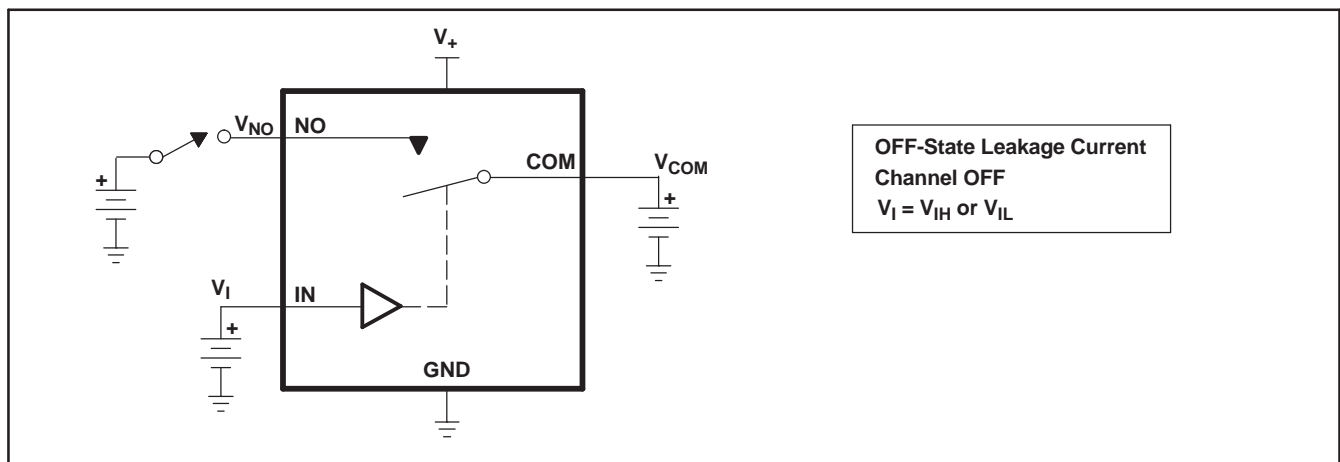

Figure 13. OFF-State Leakage Current ($I_{COM(OFF)}$, $I_{NC(OFF)}$, $I_{COM(PWR(OFF))}$, $I_{NC(PWR(FF))}$)

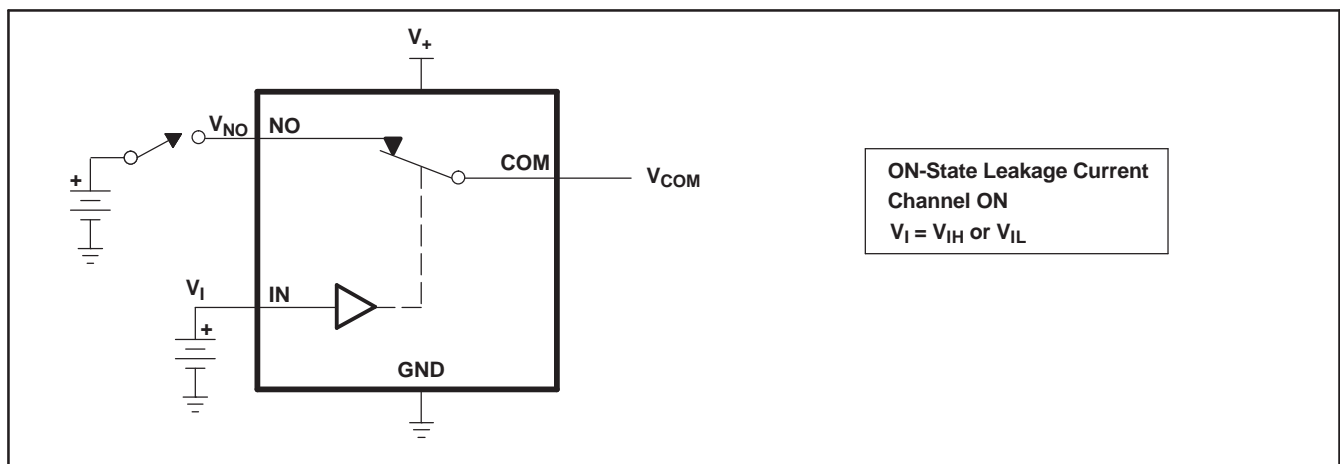

Figure 14. ON-State Leakage Current ($I_{COM(ON)}$, $I_{NC(ON)}$)

PARAMETER MEASUREMENT INFORMATION (continued)

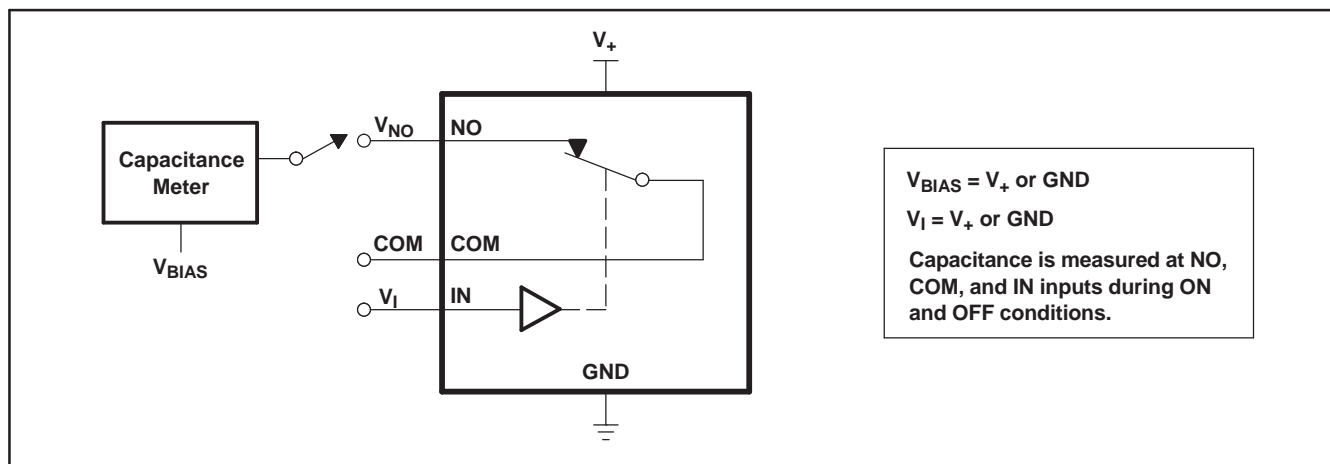
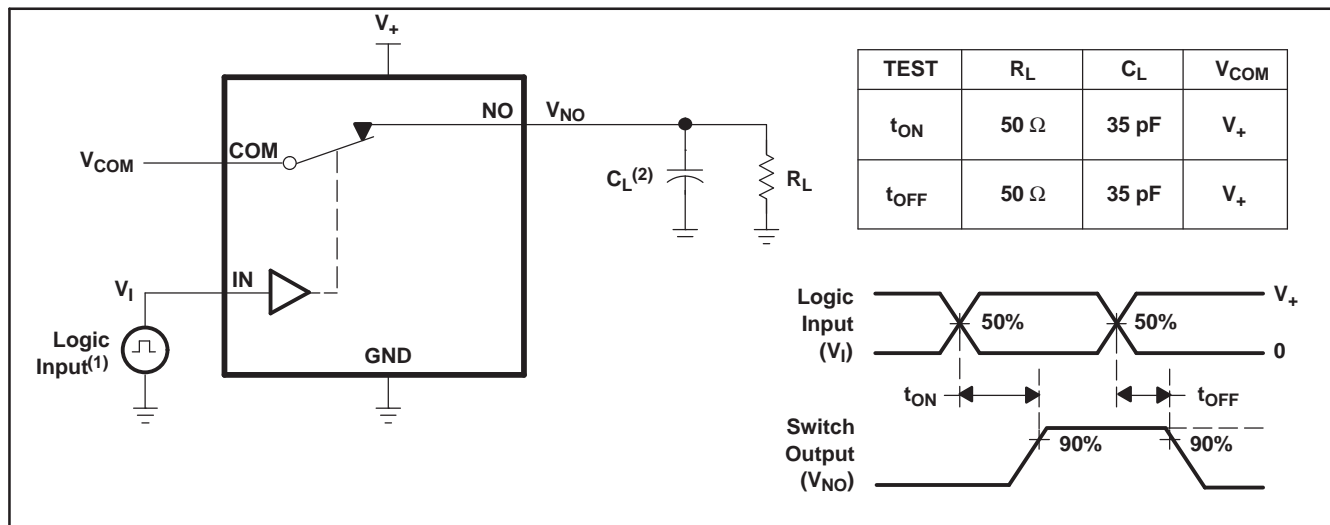

Figure 15. Capacitance (C_I , $C_{COM(OFF)}$, $C_{COM(ON)}$, $C_{NC(OFF)}$, $C_{NC(ON)}$)



(1) All input pulses are supplied by generators having the following characteristics: PRR ≤ 10 MHz, $Z_O = 50 \Omega$, $t_r < 5 \text{ ns}$, $t_f < 5 \text{ ns}$.
 (2) C_L includes probe and jig capacitance.

Figure 16. Turn-On (t_{ON}) and Turn-Off Time (t_{OFF})

PARAMETER MEASUREMENT INFORMATION (continued)

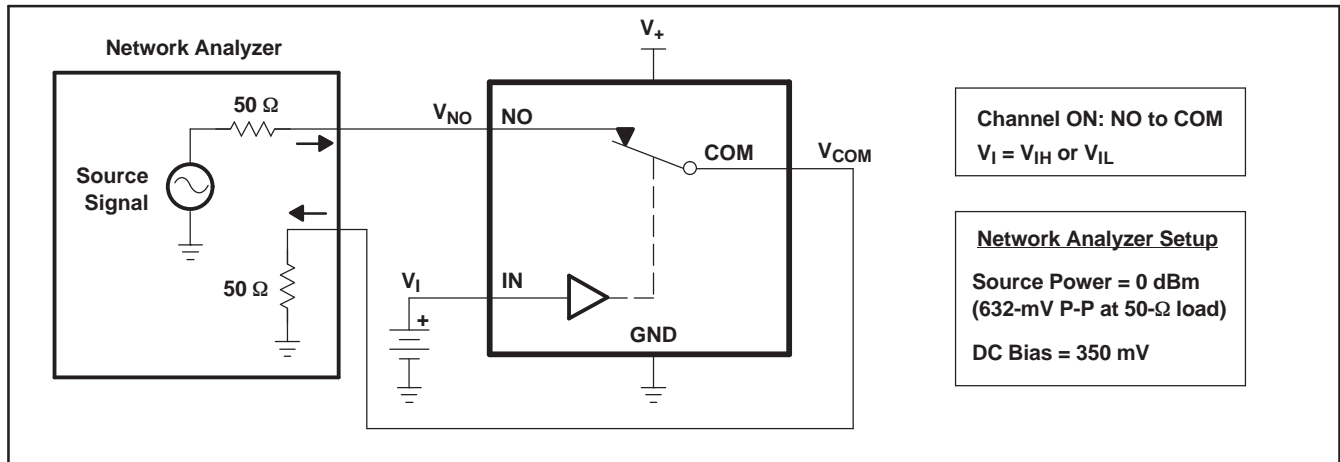

Figure 17. Bandwidth (BW)

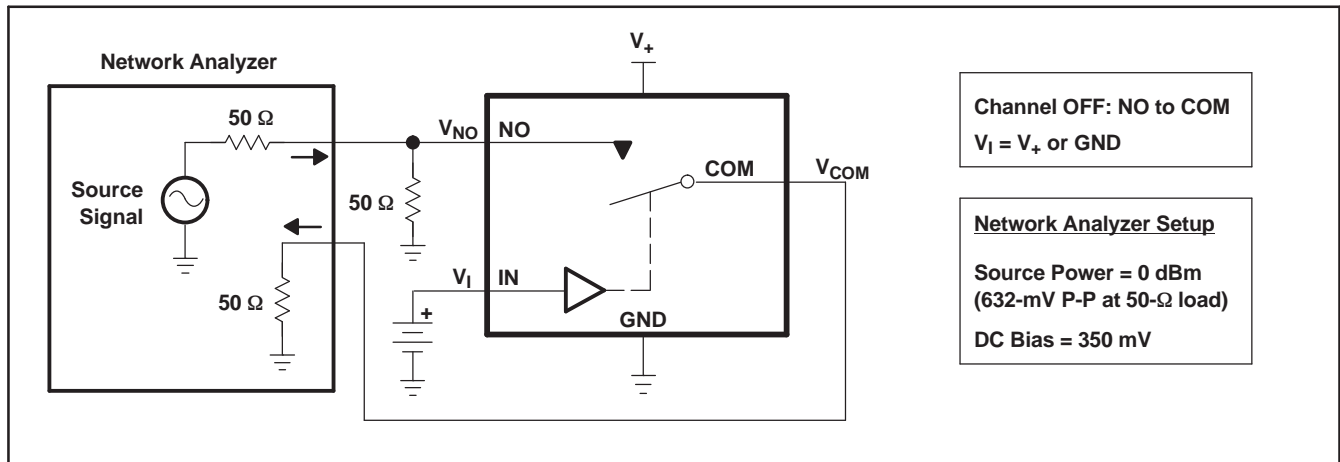

Figure 18. OFF Isolation (O_{ISO})

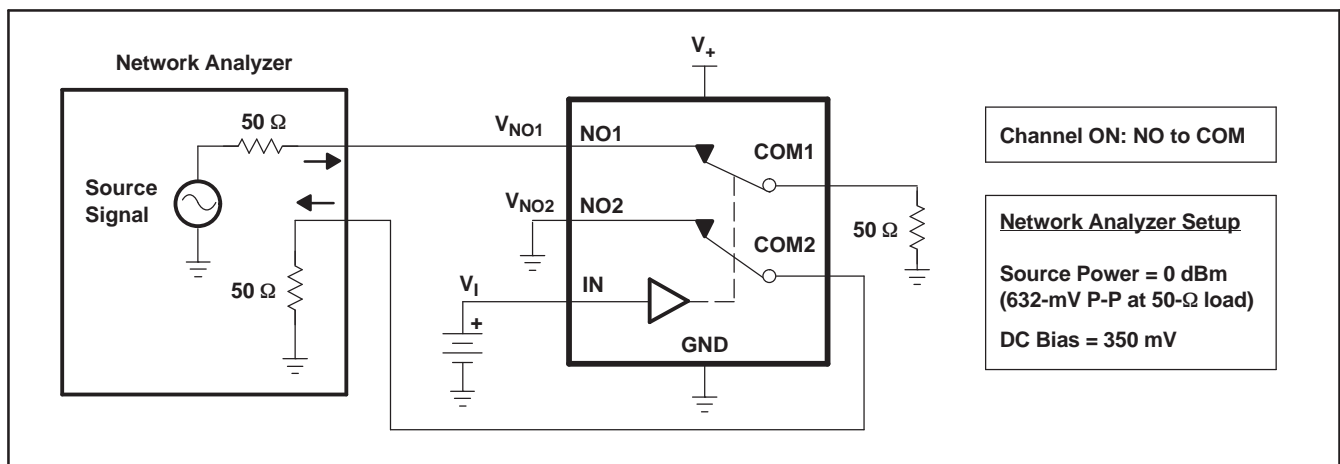
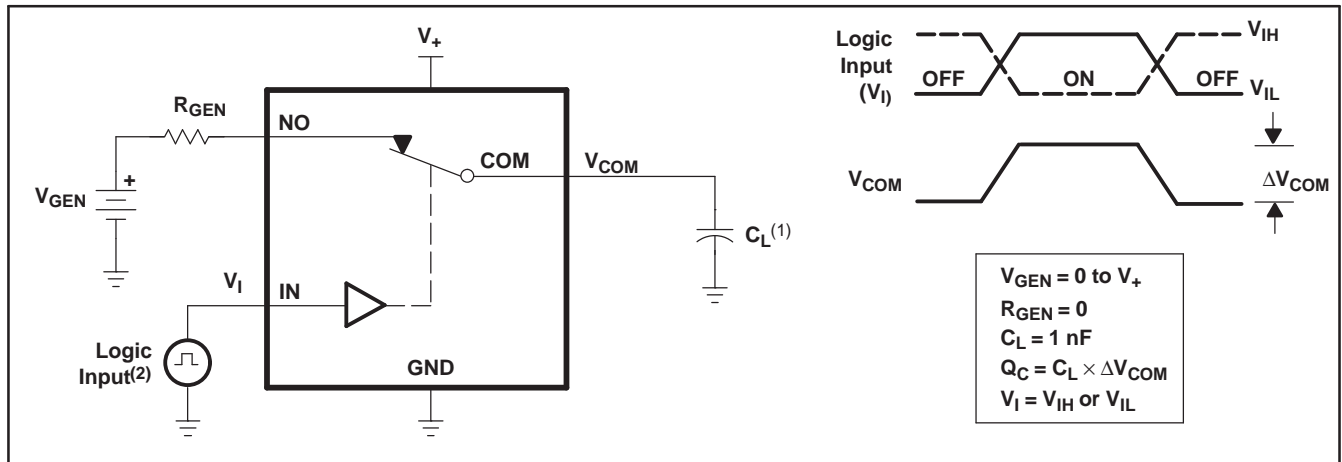

Figure 19. Crosstalk (X_{TALK})

PARAMETER MEASUREMENT INFORMATION (continued)



(1) C_L includes probe and jig capacitance.

(2) All input pulses are supplied by generators having the following characteristics: $PRR \leq 10$ MHz, $Z_O = 50 \Omega$, $t_r < 5$ ns, $t_f < 5$ ns.

Figure 20. Charge Injection (Q_C)

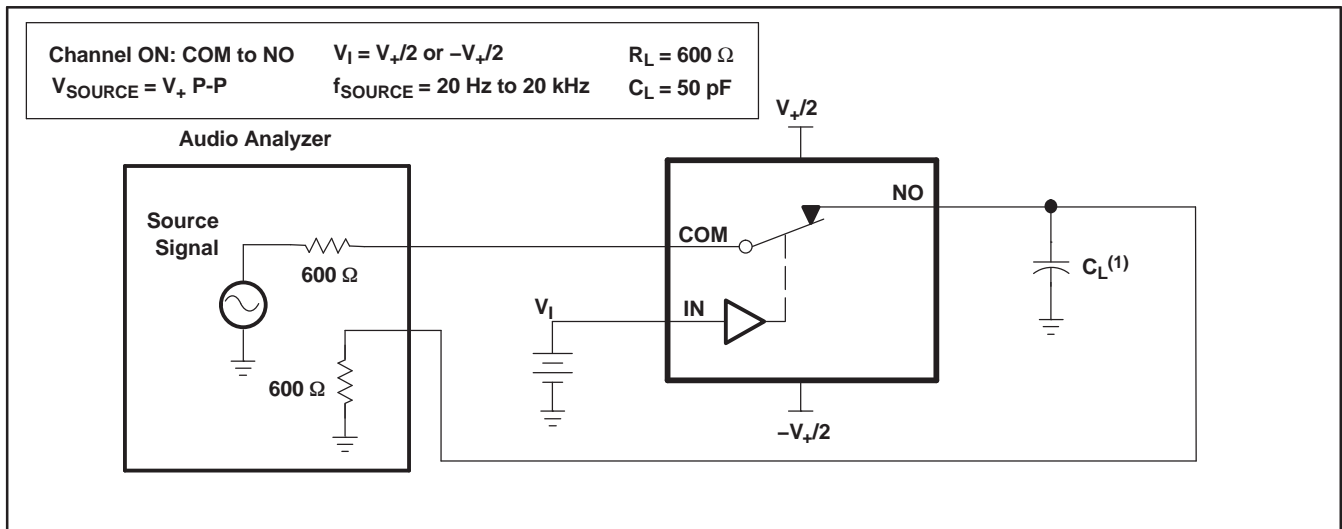

(1) C_L includes probe and jig capacitance.

Figure 21. Total Harmonic Distortion (THD)

PACKAGING INFORMATION

Orderable Device	Status ⁽¹⁾	Package Type	Package Drawing	Pins	Package Qty	Eco Plan ⁽²⁾	Lead/Ball Finish	MSL Peak Temp ⁽³⁾
TS5A23166DCUR	ACTIVE	US8	DCU	8	3000	Green (RoHS & no Sb/Br)	CU NIPDAU	Level-1-260C-UNLIM
TS5A23166DCURE4	ACTIVE	US8	DCU	8	3000	Green (RoHS & no Sb/Br)	CU NIPDAU	Level-1-260C-UNLIM
TS5A23166DCURG4	ACTIVE	US8	DCU	8	3000	Green (RoHS & no Sb/Br)	CU NIPDAU	Level-1-260C-UNLIM
TS5A23166YZPR	ACTIVE	WCSP	YZP	8	3000	Green (RoHS & no Sb/Br)	SNAGCU	Level-1-260C-UNLIM
TS5A23166YZTR	ACTIVE	DSBGA	YZT	8	3000	Green (RoHS & no Sb/Br)	SNAGCU	Level-1-260C-UNLIM

⁽¹⁾ The marketing status values are defined as follows:

ACTIVE: Product device recommended for new designs.

LIFEBUY: TI has announced that the device will be discontinued, and a lifetime-buy period is in effect.

NRND: Not recommended for new designs. Device is in production to support existing customers, but TI does not recommend using this part in a new design.

PREVIEW: Device has been announced but is not in production. Samples may or may not be available.

OBSOLETE: TI has discontinued the production of the device.

⁽²⁾ Eco Plan - The planned eco-friendly classification: Pb-Free (RoHS), Pb-Free (RoHS Exempt), or Green (RoHS & no Sb/Br) - please check <http://www.ti.com/productcontent> for the latest availability information and additional product content details.

TBD: The Pb-Free/Green conversion plan has not been defined.

Pb-Free (RoHS): TI's terms "Lead-Free" or "Pb-Free" mean semiconductor products that are compatible with the current RoHS requirements for all 6 substances, including the requirement that lead not exceed 0.1% by weight in homogeneous materials. Where designed to be soldered at high temperatures, TI Pb-Free products are suitable for use in specified lead-free processes.

Pb-Free (RoHS Exempt): This component has a RoHS exemption for either 1) lead-based flip-chip solder bumps used between the die and package, or 2) lead-based die adhesive used between the die and leadframe. The component is otherwise considered Pb-Free (RoHS compatible) as defined above.

Green (RoHS & no Sb/Br): TI defines "Green" to mean Pb-Free (RoHS compatible), and free of Bromine (Br) and Antimony (Sb) based flame retardants (Br or Sb do not exceed 0.1% by weight in homogeneous material)

⁽³⁾ MSL, Peak Temp. -- The Moisture Sensitivity Level rating according to the JEDEC industry standard classifications, and peak solder temperature.

Important Information and Disclaimer:The information provided on this page represents TI's knowledge and belief as of the date that it is provided. TI bases its knowledge and belief on information provided by third parties, and makes no representation or warranty as to the accuracy of such information. Efforts are underway to better integrate information from third parties. TI has taken and continues to take reasonable steps to provide representative and accurate information but may not have conducted destructive testing or chemical analysis on incoming materials and chemicals. TI and TI suppliers consider certain information to be proprietary, and thus CAS numbers and other limited information may not be available for release.

In no event shall TI's liability arising out of such information exceed the total purchase price of the TI part(s) at issue in this document sold by TI to Customer on an annual basis.

TAPE AND REEL INFORMATION

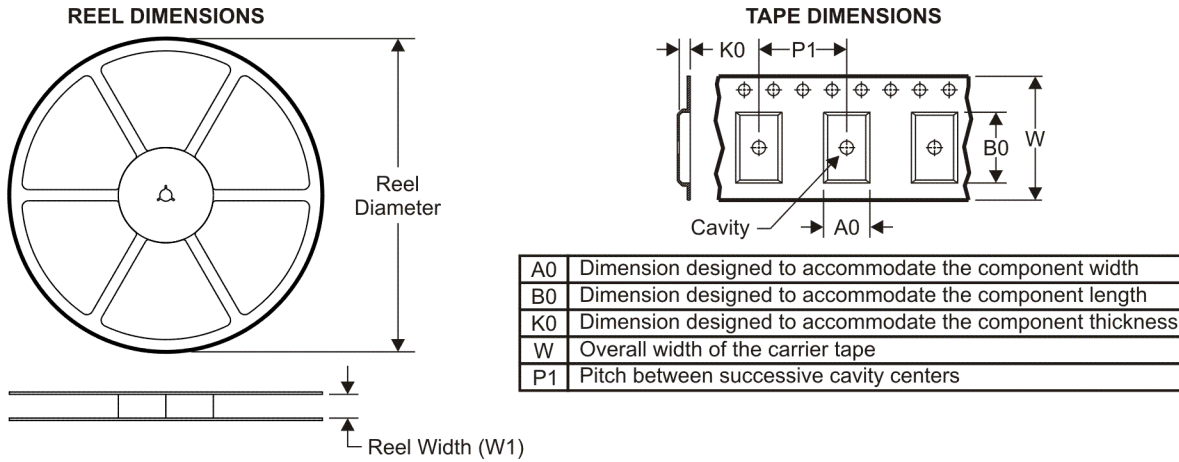

QUADRANT ASSIGNMENTS FOR PIN 1 ORIENTATION IN TAPE

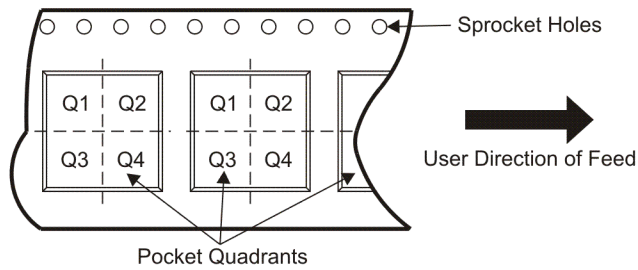

*All dimensions are nominal

Device	Package Type	Package Drawing	Pins	SPQ	Reel Diameter (mm)	Reel Width W1 (mm)	A0 (mm)	B0 (mm)	K0 (mm)	P1 (mm)	W (mm)	Pin1 Quadrant
TS5A23166DCUR	US8	DCU	8	3000	180.0	9.2	2.25	3.35	1.05	4.0	8.0	Q3
TS5A23166YZTR	DSBGA	YZT	8	3000	180.0	8.4	1.1	2.1	0.7	4.0	8.0	Q1

TAPE AND REEL BOX DIMENSIONS

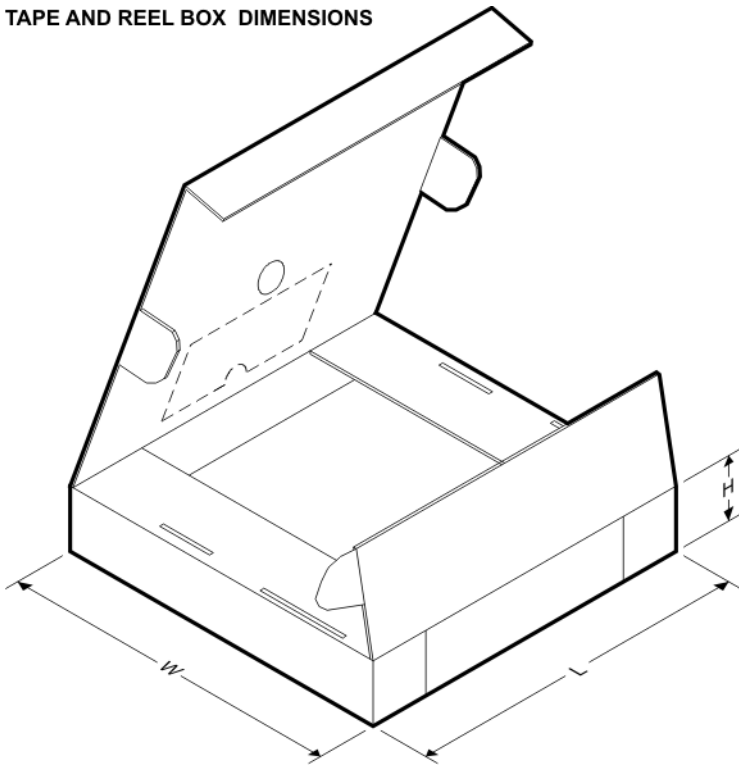

*All dimensions are nominal

Device	Package Type	Package Drawing	Pins	SPQ	Length (mm)	Width (mm)	Height (mm)
TS5A23166DCUR	US8	DCU	8	3000	202.0	201.0	28.0
TS5A23166YZTR	DSBGA	YZT	8	3000	220.0	220.0	34.0

YZP (R-XBGA-N8)

DIE-SIZE BALL GRID ARRAY

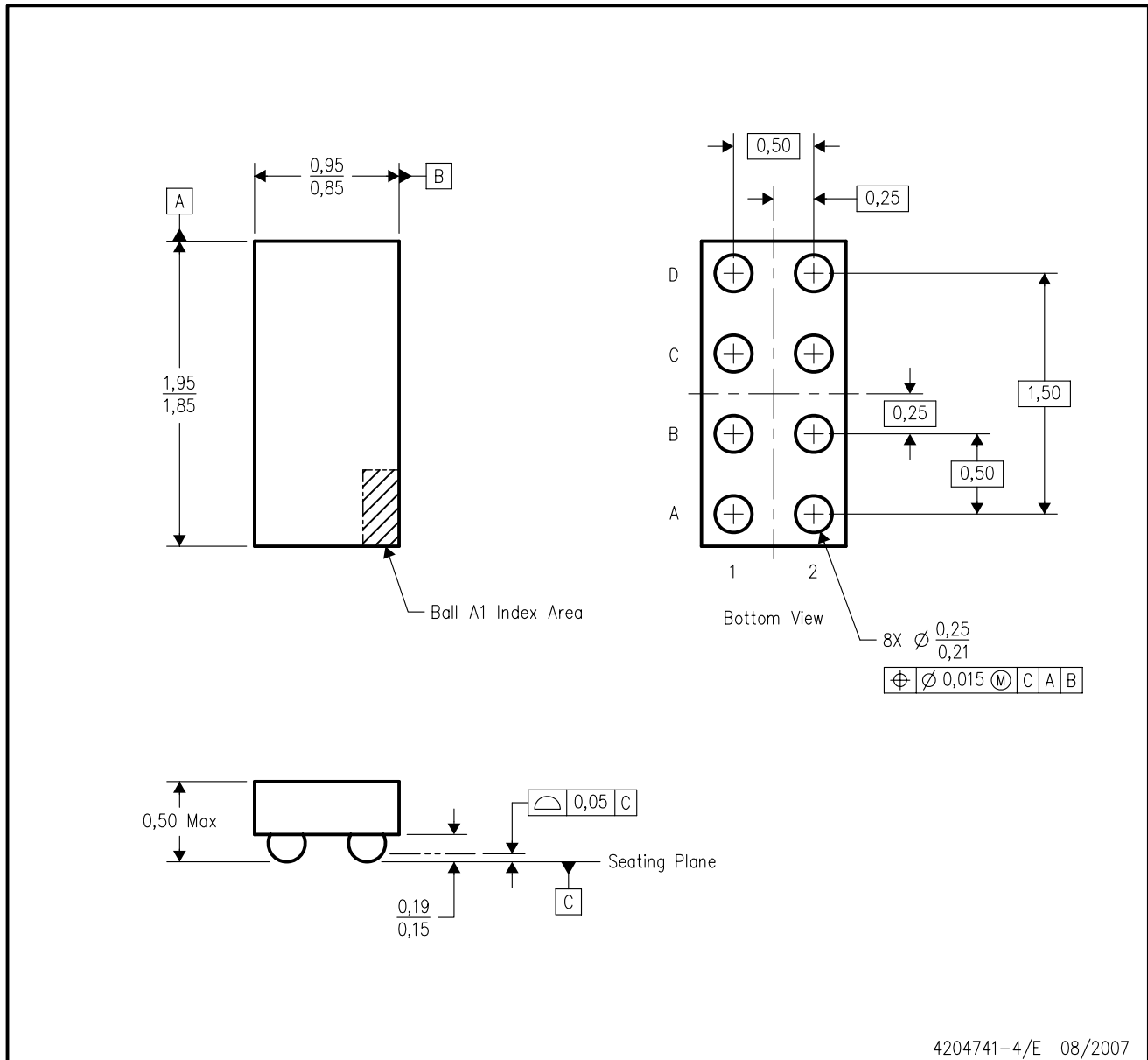

- NOTES:
- A. All linear dimensions are in millimeters. Dimensioning and tolerancing per ASME Y14.5M-1994.
 - B. This drawing is subject to change without notice.
 - C. NanoFree™ package configuration.
 - D. This package is lead-free. Refer to the 8 YEP package (drawing 4204725) for tin-lead (SnPb).

NanoFree is a trademark of Texas Instruments.

YZT (R-XBGA-N8)

DIE-SIZE BALL GRID ARRAY

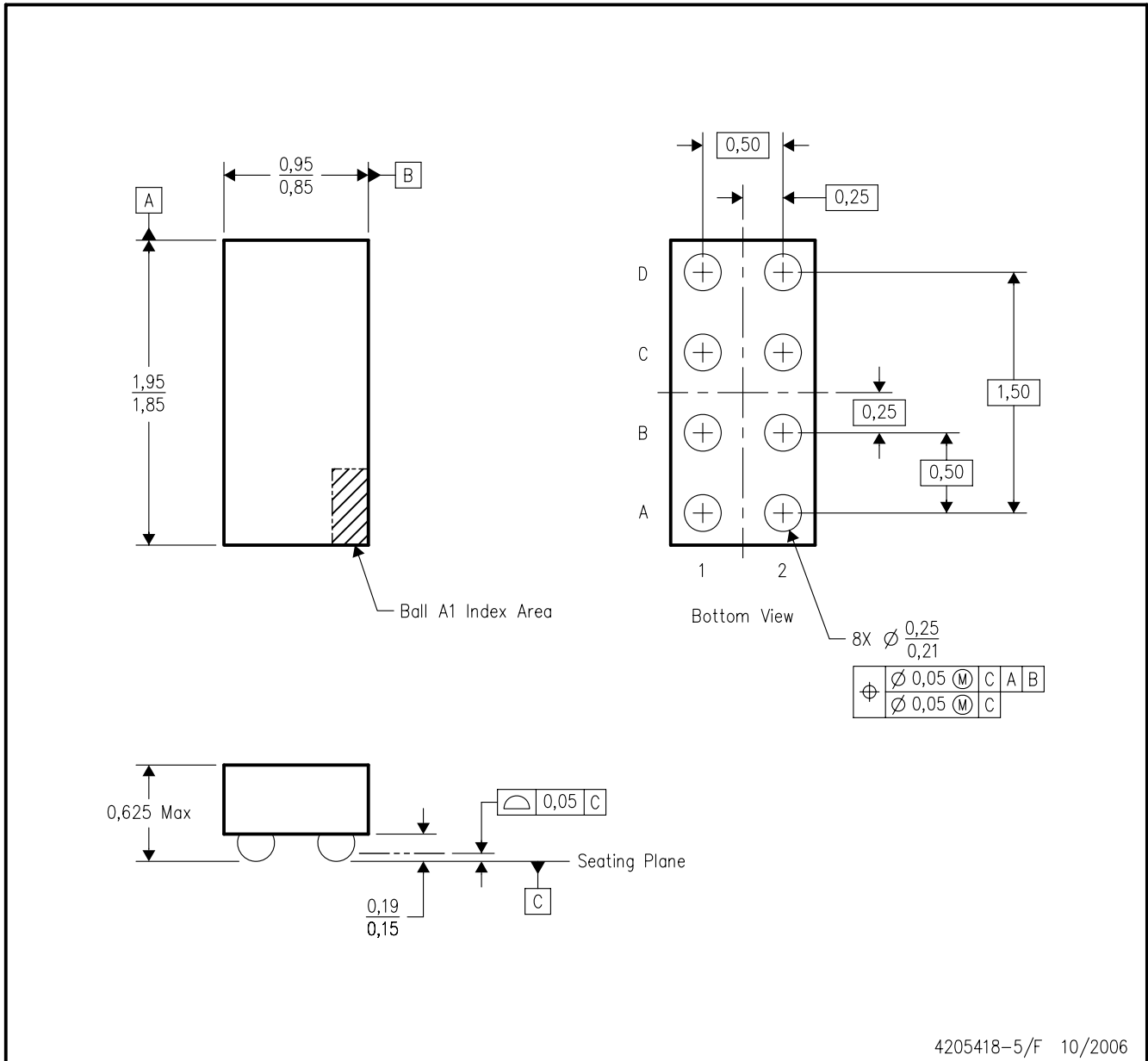

- NOTES:
- A. All linear dimensions are in millimeters.
 - B. This drawing is subject to change without notice.
 - C. NanoFree™ package configuration.
 - D. This package is Lead-free. Refer to the 8 YET package (drawing 4205421) for tin-lead (SnPb).

NanoFree is a trademark of Texas Instruments.

IMPORTANT NOTICE

Texas Instruments Incorporated and its subsidiaries (TI) reserve the right to make corrections, modifications, enhancements, improvements, and other changes to its products and services at any time and to discontinue any product or service without notice. Customers should obtain the latest relevant information before placing orders and should verify that such information is current and complete. All products are sold subject to TI's terms and conditions of sale supplied at the time of order acknowledgment.

TI warrants performance of its hardware products to the specifications applicable at the time of sale in accordance with TI's standard warranty. Testing and other quality control techniques are used to the extent TI deems necessary to support this warranty. Except where mandated by government requirements, testing of all parameters of each product is not necessarily performed.

TI assumes no liability for applications assistance or customer product design. Customers are responsible for their products and applications using TI components. To minimize the risks associated with customer products and applications, customers should provide adequate design and operating safeguards.

TI does not warrant or represent that any license, either express or implied, is granted under any TI patent right, copyright, mask work right, or other TI intellectual property right relating to any combination, machine, or process in which TI products or services are used. Information published by TI regarding third-party products or services does not constitute a license from TI to use such products or services or a warranty or endorsement thereof. Use of such information may require a license from a third party under the patents or other intellectual property of the third party, or a license from TI under the patents or other intellectual property of TI.

Reproduction of TI information in TI data books or data sheets is permissible only if reproduction is without alteration and is accompanied by all associated warranties, conditions, limitations, and notices. Reproduction of this information with alteration is an unfair and deceptive business practice. TI is not responsible or liable for such altered documentation. Information of third parties may be subject to additional restrictions.

Resale of TI products or services with statements different from or beyond the parameters stated by TI for that product or service voids all express and any implied warranties for the associated TI product or service and is an unfair and deceptive business practice. TI is not responsible or liable for any such statements.

TI products are not authorized for use in safety-critical applications (such as life support) where a failure of the TI product would reasonably be expected to cause severe personal injury or death, unless officers of the parties have executed an agreement specifically governing such use. Buyers represent that they have all necessary expertise in the safety and regulatory ramifications of their applications, and acknowledge and agree that they are solely responsible for all legal, regulatory and safety-related requirements concerning their products and any use of TI products in such safety-critical applications, notwithstanding any applications-related information or support that may be provided by TI. Further, Buyers must fully indemnify TI and its representatives against any damages arising out of the use of TI products in such safety-critical applications.

TI products are neither designed nor intended for use in military/aerospace applications or environments unless the TI products are specifically designated by TI as military-grade or "enhanced plastic." Only products designated by TI as military-grade meet military specifications. Buyers acknowledge and agree that any such use of TI products which TI has not designated as military-grade is solely at the Buyer's risk, and that they are solely responsible for compliance with all legal and regulatory requirements in connection with such use.

TI products are neither designed nor intended for use in automotive applications or environments unless the specific TI products are designated by TI as compliant with ISO/TS 16949 requirements. Buyers acknowledge and agree that, if they use any non-designated products in automotive applications, TI will not be responsible for any failure to meet such requirements.

Following are URLs where you can obtain information on other Texas Instruments products and application solutions:

Products

Amplifiers	amplifier.ti.com
Data Converters	dataconverter.ti.com
DSP	dsp.ti.com
Clocks and Timers	www.ti.com/clocks
Interface	interface.ti.com
Logic	logic.ti.com
Power Mgmt	power.ti.com
Microcontrollers	microcontroller.ti.com
RFID	www.ti-rfid.com
RF/IF and ZigBee® Solutions	www.ti.com/lprf

Applications

Audio	www.ti.com/audio
Automotive	www.ti.com/automotive
Broadband	www.ti.com/broadband
Digital Control	www.ti.com/digitalcontrol
Medical	www.ti.com/medical
Military	www.ti.com/military
Optical Networking	www.ti.com/opticalnetwork
Security	www.ti.com/security
Telephony	www.ti.com/telephony
Video & Imaging	www.ti.com/video
Wireless	www.ti.com/wireless

Mailing Address: Texas Instruments, Post Office Box 655303, Dallas, Texas 75265
Copyright © 2008, Texas Instruments Incorporated